



Outstanding rough terrain driving features

- 4 wheel drive
- Automatic differential lock
- Excellent gradeability (40%)
- Ground clearance of 27 cm

Robust and easy to maintain

- Outriggers positioned within the machine footprint
- Durable and reliable upper control box
- Optimized accessibility to components
- Built-in diagnosis tool

Exceptional productivity

- Full proportional controls
- Narrow turning radius
- One switch to deploy and retract 4 outriggers



TECHNICAL DATA

Compact 10 DX Compact 12 DX

Working height	10.15 m	12.15 m
Platform height	8.15 m	10.15 m
Driveable at full height up to	8.15 m	10.15 m
Lift capacity	565 kg	450 kg
A Length	3.17 m	3.17 m
B Width	1.8 m	1.8 m
C Height - stowed	2.43 m	2.55 m
Storage height	1.57 m	1.7 m
F Platform length	2.5 m	2.5 m
Extended platform length	3.7 m	3.7 m
Platform extension length	1.2 m	1.2 m
G Platform width	1.54 m	1.54 m
D Wheelbase	1.87 m	1.87 m
E Ground clearance	27 cm	27 cm
Number of extensions	1	1
Drive speed	0,8 - 5,5 km/h	0,8 - 5,5 km/h
Turning radius - outside	3.5 m	3.5 m
Lift / lower speed	35s / 46 s	40s / 51s
Engine	18.5 kw - 24.8 hp	18.5 kW - 24.8 hp
Gradeability	40 %	40 %
Tires - foam-filled	26x12-16.5	26x12-16.5
Hydraulic system capacity	75 l	75 l
Weight	3440 kg	4060 kg

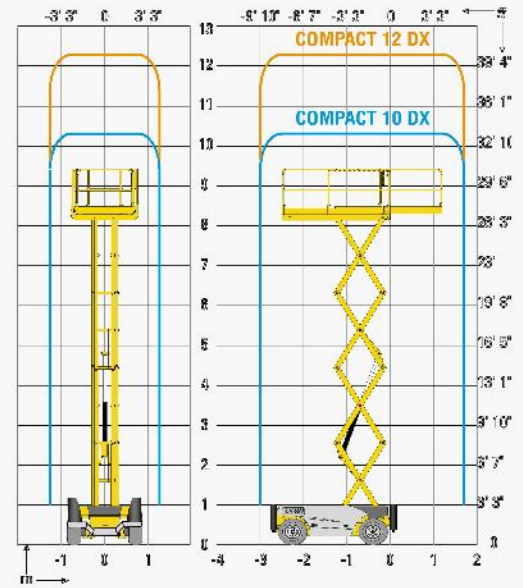
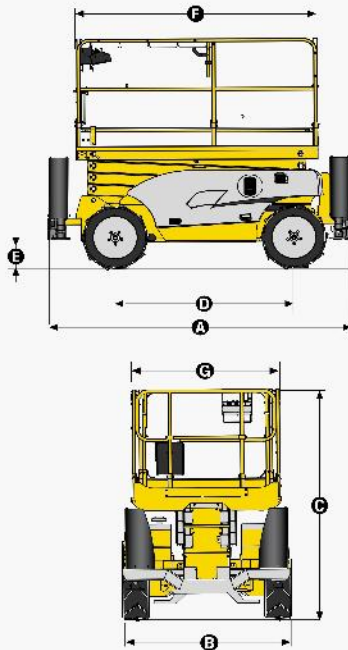

STANDARD EQUIPMENT

- ③ Kubota engine
- ③ 4 wheel drive, 2 wheel steer
- ③ 3° Tilt alarm
- ③ 1,2m platform extension
- ③ 12V - 74 Ah Batteries
- ③ Removable operator's control box
- ③ Brake release
- ③ Hourmeter
- ③ Towing hooks
- ③ Hydraulic brakes
- ③ Manual platform lowering valve
- ③ Foam filled all terrain tyres
- ③ Automatic levelling outriggers
- ③ Horn
- ③ Lanyard attachment points

OPTIONS AND ACCESSORIES

- ③ Non marking tyres
- ③ Rotating beacon
- ③ Power line in platform
- ③ Travel alarm
- ③ Motion alarm for movements and translation
- ③ Working light
- ③ Catalytic exhaust
- ③ Biodegradable oil
- ③ Cold Weather Package
- ③ Swing-door gate
- ③ Foldable guard-rails
- ③ Hydraulic generator 3.5 kW